



Features:

- Single microphone input operates two different or similar radio brands.
- Condenser Microphone power furnished by active radio
- BAL/UNBAL selectable input for M2
- Foot Switch input bridged with microphone PTT
- External amplifier key line
- ALC routing selector via R1/R2 switch
- Internal 8 pin connector set R1/R2 for Yaesu/ICOM/Kenwood/Alinco
 - Will work with other similar pinout radio brands
- Passive relay routing R1/R2 selects:
 - MIC / MIC Ground
 - PTT / Phantom Power
- LED Panel Indicators provide quick glance operating condition.
- Includes 12Vdc Adapter, 3ft Foster Female to Female cable, 3.5mm TRS to XLR adapter

NOTE: The MCI-102 was designed for compatibility with Yaesu/ICOM/Kenwood/Alinco desktop radios. Mobile radios do not always follow the same connection conventions as desktop counterparts. When considering use with mobile radios it is best to Email Techsupport@AALogic.com with request to verify mobile radio brand and model compatibility.

Function List:

- PWR: Turns on external supply for relay routing.
- KeyEN (ON):
 - Rear panel Key COM connector: Foot Switch/Mic PTT Key Line R1/R2 common, Max MOSFET switching 120Vdc/15mA (-40Vdc/10mA).
 - Key R1/R2: Key COM routed to selected radio via SPDT relay
- KeyEN (OFF):
 - Removal of internal jumper allows SPDT relay to be used as an external R1/R2 control line (1A 125Vac, 2A 30Vdc)
- R1/R2:
 - Activates corresponding ALC and Key lines.
 - Provides passive relay routing for the selected microphone input to R1/R2.
 - Microphone and microphone return
 - PTT and radio Microphone Power to selected microphone.
- M1/M2:
 - Routes selected microphone to selected R1/R2
 - Internal 8 pin connector matrix provides correct wiring to desired radio.
 - M1A specific for Yaesu FT991A/FT710/FTDX10.
 - M1B supports FTDX101/ICOM/Kenwood, or others brands correlating with associated selection.
 - M2 uses internal jumpers to select between BAL or UNBAL microphones.
 - M2 and M1 internal jumper setting can provide Voltage from selected R1/R2 to power condenser microphones.
- FT SW:
 - Standard ¼ TS phone jack
 - Bridged to work in conjunction with hand microphone PTT.
- M2:
 - 3.5mm TRS, TS unbalanced, TRS balanced, internal selectable
 - Jumper setting for phantom power.
- ALC Routing:
 - Selectable via front panel R1/R2 switch
 - SPDT relay contact (1A 125Vac, 2A 30Vdc)

NOTE: Additional microphone functionality only available on R1 for native M1.

(example: Kenwood UP/DWN control requires M1 and R1 internal selection for Kenwood.)

Overview

With the exception of the keying circuits the MCI-102 is a purely passive routing selector. **Figure 1 shows jumper locations, and Figure 2 below provides an overview of internal connections.** Signal routing is done using a set of pre-wired jumpers. Signals including MIC, MIC GND, PTT, PTT GND, and microphone power are selected with front panel toggles and DPDT relays.

Each radio input has its own matrix for selecting Kenwood/Alinco, ICOM, Yaesu RJ-45 (ethernet type), and Yaesu Foster (GX-16-8 Aviation). The input microphone device is also jumper selectable to match configurations for MIC 1A. MIC 1B is fixed for Yaesu RJ45 type radios. In addition to the above relayed routed signals, other microphone functions are available when the connected microphone matches the selected radio (i.e. Yaesu Mic to Yaesu radio, UP/DWN control).

Microphone input MIC 2 is provided to allow more generic inputs. These include a variety of Heil microphones, and other types found for audio and computer systems.

A rear panel ¼" Tip/Sleeve jack allows for a foot switch or other keying device. This circuit is in parallel with M1A/B microphone push button transmit switch. When enabled by front panel "Key En" toggle, the associated rear panel RCA jack is grounded. The Common RCA can be used when either radio is selected, or RCA for radio 1 or radio 2 for the radio selected by front panel R1/R2 toggle switch.

Rear panel RCA jacks ALC, R1, R2 are controlled by R1/R2 toggle to offer a contact closure that can be used to route signaling from amplifier to selected radio, or as an external antenna relay control.

Jumper JP1:

Front Panel "Key-EN" provides ground keying output when Foot or Hand Switch is activated. Jumper position 1&2 will pull positive signals to ground whereas position 2&3 grounds negative inputs. Rear Panel RCA "Key COM" provides key output for both R1/R2 selection, whereas R1 and R2 are relative to selected radio.

Jumper JP2:

The "DRY" jumper is used when microphone M1 does not require external power to operate (standard dynamic), or the selected radio furnishes power through the MIC lead such as those found on ICOM radios.

In the case where the selected radio doesn't furnish power on the MIC lead and the microphone requires power, set this jumper to "WET". Since Yaesu uses dynamic microphones and no power is applied to the MIC line, one such condition would be when using an ICOM microphone connected to a Yaesu FT-991A radio. The "WET" jumper position routes power from the selected radio to the attached MIC 1 microphone.

Jumper JP3:

JP3 serves the same function as JP2 above. If the attached microphone MIC 2 requires battery to function, select "WET", otherwise "DRY".

Jumper JP4:

Installing this jumper will route MCI-102 12Vdc to the wiper of the ALC selector relay (RCA Common). Associated R1/R2 jacks can be used to control external 12Vdc antenna relays or other optional devices dependent on radio selection. Leave this jumper open if these relay contacts are being used for ALC control.

Jumper JP21:

Jumpers JP21 are used to select between direct balanced, balanced isolated, and unbalanced isolated. Isolated selection utilizes a 600:600 ohm transformer to help eliminate potential ground loops or coupled RF signals.

Direct Balanced: JP1-2, 3-4

XFMR Balanced: JP5-6, 7-8, 9-10, 11-12

XFMR Un-Balanced: JP5-6, 7-8, 9-10, 13-14

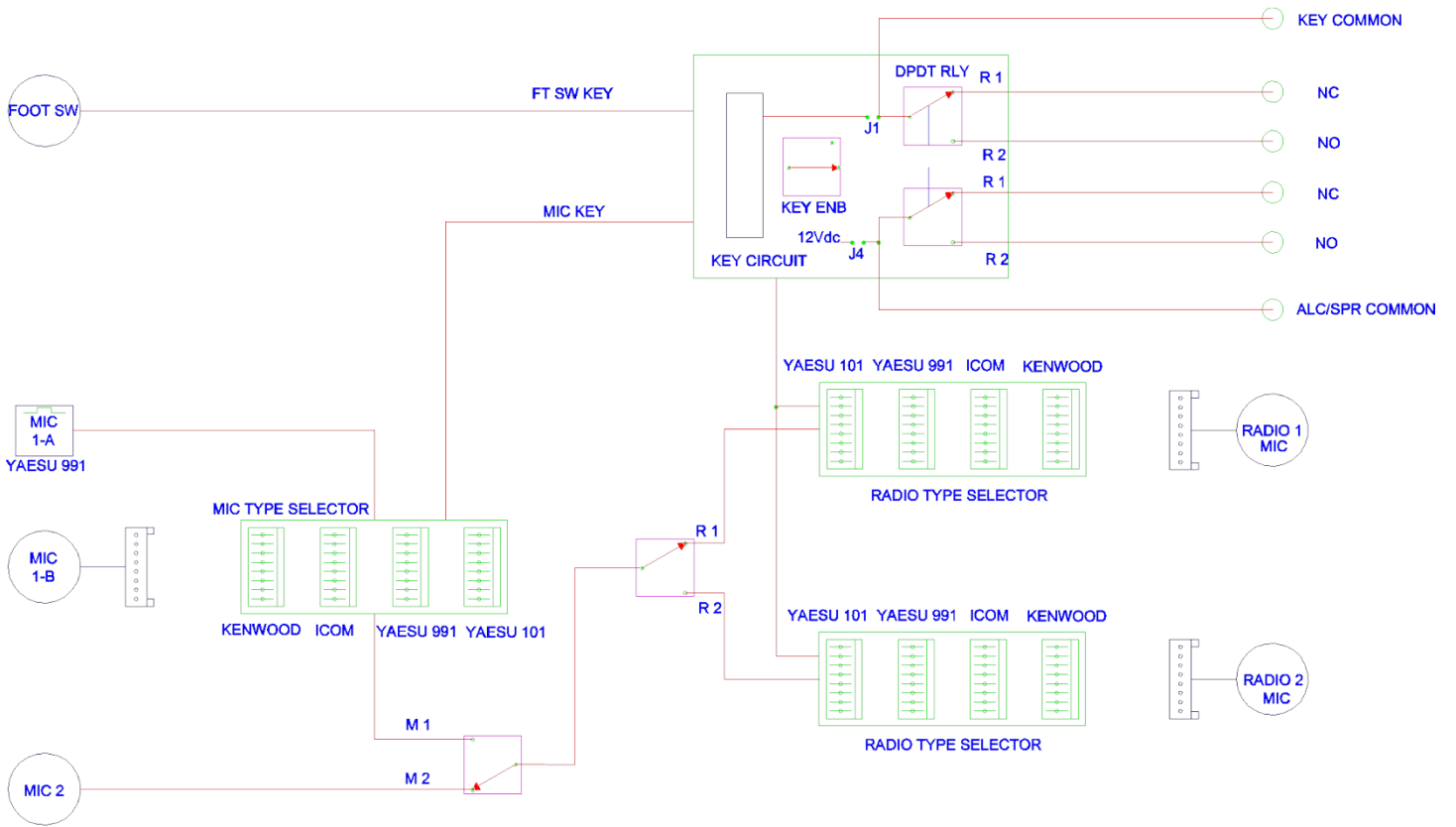

MCI-102 BLOCK DIAGRAM

FIGURE 2